



Installation Instructions

Garage Door Opener Radio Controls

Model 5010 (300 mHz) \ 5012 (310 mHz) Single Button Transmitters

Model 5020 (300 mHz) \ 5022 (310 mHz) Dual Button Transmitters

Model 5100-01 (300 mHz) \ 5102-01 (310 mHz) Receivers

WARNING:

- **Disconnect operator power before any installation or repair**
- **Always wear safety glasses**

Your Digi-Code radio controls are designed specifically to remotely control a garage door opener from within an automobile and to give years of trouble free service without adjustment. **Because all radio controls are set with the even numbered switches in the “ON” position when they leave the factory, it is recommended that a different code be selected and set at the time of installation.** Please refer to the “Setting the Code Switch” section for instructions. The radio frequency (RF) portion of the controls, however, are tuned to standard frequencies and are thoroughly tested at the factory. This permits the addition or replacement of either the transmitter or the receiver by specifying the Model number and the RF frequency designated on the identification label. RF adjustments are not needed nor should any be attempted.

SECTION #1

RECEIVER INSTALLATION

The receiver is designed to mount directly to the operator. It can be remotely installed if the operator terminal strip is not accessible, or if the power for the receiver is not obtainable from the operator. To direct mount the receiver, simply loosen the terminal screws on the operator and insert the two-way lugs from the receiver under the screw heads along the wall button wires, and tighten the screws (See Figure #1)

Place the antenna (a 10 inch black wire) in a vertical position as far from any metal as possible.

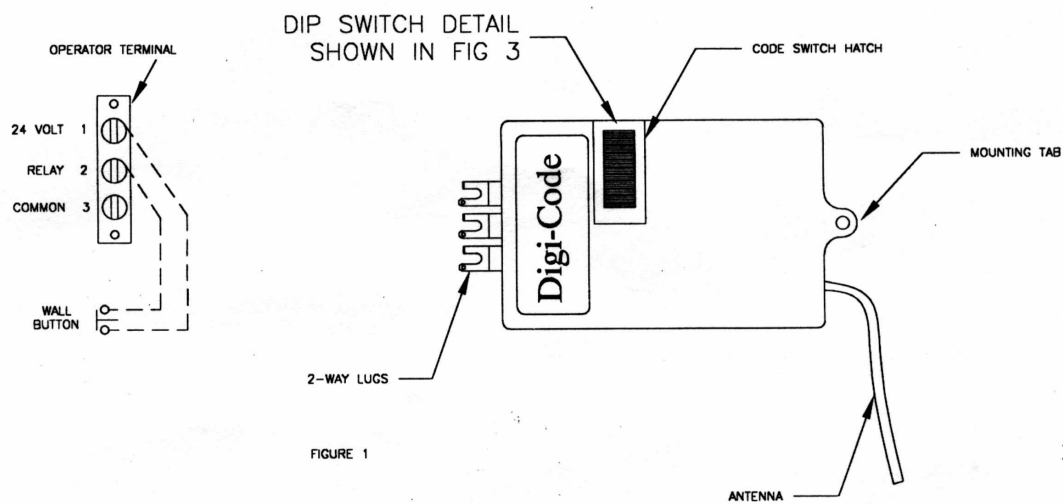

FIGURE 1

For remote installation the receiver may be mounted near the operator head on a joist or the ceiling by using the mounting tab. Order Model 5192-06 adapter, which permits connection between the operator terminal and the two-way lugs on the receiver.

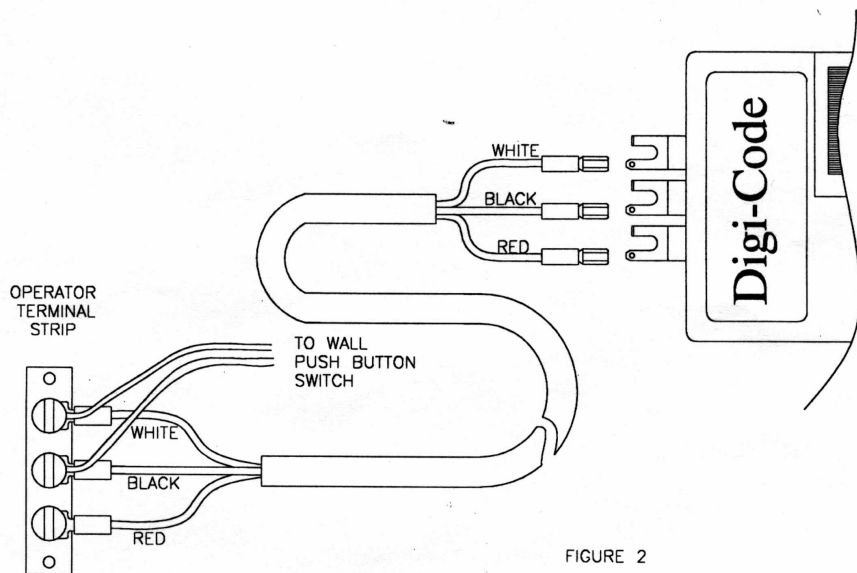

FIGURE 2

Slip on connectors at one end of the adapter connect to the flat side of each spade lug on the receiver, and the spade connectors at the other end connect to the operator terminal.

Connect wires as follows:

- (a) White wire to terminal "1" or "24v"
- (b) Black wire to terminal "2" or "Relay"
- (c) Red wire to terminal "3" or "Common" (Radio Power)
- (d) Connect push button wires to terminal "1" and "2" (See Figure #2)

Where power for the radio receiver is not available from the operator order a Model 5192-01 power transformer adapter for connection between the operator and the remote receiver.

SECTION #2

SETTING THE ("RECEIVER") CODE SWITCH - TO WORK WITH MODEL 5010 AND MODEL 5012 SINGLE BUTTON TRANSMITTERS

Use your finger to slide the "code switch hatch" from the receiver for access to the code switch. On the transmitter the entire front lower half of the case (" the battery hatch") is removeable. Use a coin or the curved end of the visor clip to disengage the lower half of the transmitter front. This will expose both the code switch and the battery compartment (See Figure #3).

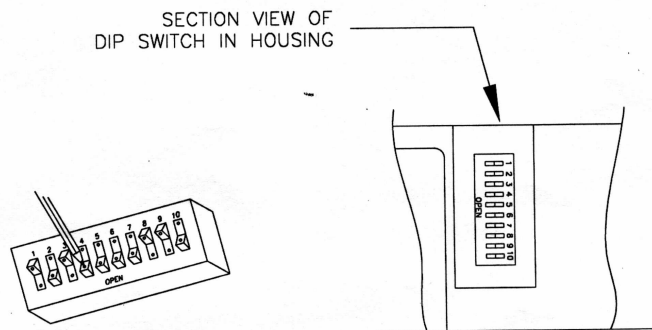
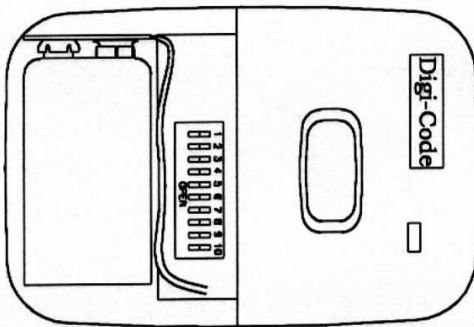

FIGURE 3



Model – 5010 (300mHz) or 5012 (310mHz)

Figure #3A

Set both code switches to the code of your choice, being sure both are set the same since a different setting of just one switch will prevent operation. The digital code is determined by the position of the 10 small switches numbered 1 through 10 located in the receiver and the transmitter. Any combination of "on" or "off" positions can be selected by using a pencil or a pen. (Note: The switches are in the "on" position when the switch is depressed toward the number.) See Figure #3 above.

Once the codes have been set, check operation and reinsert the hatches.

SECTION #3

SETTING THE (“RECEIVER”) CODE SWITCHES - TO WORK WITH MODEL 5020 AND MODEL 5022 DUAL BUTTON TRANSMITTERS

Use your finger to slide the “code switch hatch” from the receiver for access to the code switch. On the transmitter the entire front lower half of the case (“ the battery hatch”) is removeable. Use a coin or the curved end of the visor clip to disengage the lower half of the transmitter front. This will expose both the code switch and the battery compartment. See Figure #3 (Receiver) above and Figure #4 (Dual Button Transmitter) below.

Figure #4

Model – 5020 (300mHz) or 5022 (310mHz)

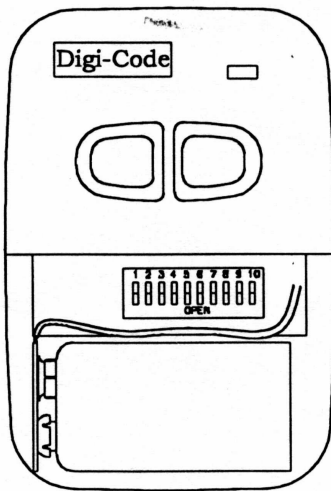

Before setting the receiver code switches, you will need to set the transmitter code switch on your model 5020 or 5022. We strongly suggest that you change the code from the factory setting to provide security for your own system, and to eliminate interference with neighboring systems.

SETTING THE TRANSMITTER CODE SWITCH – MODEL’S 5020 & 5022

On the transmitter the entire front lower half of the case (“ the battery hatch”) is removeable. Use a coin or the curved end of the visor clip to disengage the lower half of the transmitter front. This will expose both the code switch and the battery compartment. Once you have done this, locate the code switch and set code switch positions 1 through 9 to your personal code scheme (***THE 10TH POSITION SWITCH MUST BE SET IN THE CLOSED POSITION “ON”***), (Note: The switch is in the “on” position when it is depressed toward the number.). We strongly urge that several coding schemes be avoided: ALL ON; 2,4,6,8,10, ON. These positions are similar to our or other manufacturers test positions, or are frequently used.

SETTING RECEIVER #1 (WORKS WITH LEFT BUTTON ON TRANSMITTER)

Use your finger to slide the “code switch hatch” from the receiver for access to the code switch. Set the receiver code switch positions 1 through 9 to match the transmitter code switch. **Then make sure that the 10th position switch on receiver #1 is set in the closed position “ON”.** The left button on the transmitter should now operate this receiver.

Once the codes have been set, check operation and reinsert the hatches.

SETTING RECEIVER #2 (WORKS WITH RIGHT BUTTON ON TRANSMITTER)

Use your finger to slide the “code switch hatch” from the receiver for access to the code switch. Set the receiver code switch positions 1 through 9 to match the transmitter code switch. **Then make sure that the 10th position switch on receiver #2 is set in the open position “OFF”.** The right button on the transmitter should now operate this receiver.

Once the codes have been set, check operation and reinsert the hatches.

SECTION #4

SETTING THE TRANSMITTER CODE SWITCH – TO WORK WITH EXISTING STANLEY GARAGE DOOR OPENERS (Models 5012 & 5022 only)

Set the transmitter using “**SETTING THE TRANSMITTER CODE SWITCH – MODEL’S 5020 & 5022**” instructions from section #3 above.

Set the first garage door opener using “**SETTING RECEIVER #1 (WORKS WITH LEFT BUTTON ON TRANSMITTER)**” instructions from section #3 above.

Set the second garage door opener using “**SETTING RECEIVER #2 (WORKS WITH RIGHT BUTTON ON TRANSMITTER)**” instructions from section #3 above.

SECTION #5

TRANSMITTER BATTERY REPLACEMENT

The battery in the transmitter can be checked or changed by removing the front lower half of the transmitter. Use a coin or the curved end of the visor clip to disengage the lower half of the transmitter front. This will expose the battery compartment. Replacement battery must be a 9-volt.

TO REPLACE OR ADD A SET

A replacement or new transmitter or receiver may be purchased by specifying the Model Number and the RF frequency designated on the serial tag label. The RF frequency is set at the factory and must not be adjusted in the field. The digital code can be matched to the companion receiver or transmitter by following the “setting” procedures above.

OPERATIONAL CHECK

To check operation, move back about 50 feet and press the transmitter button. Operation should be reliable at this distance but environment and location of both the transmitter and receiver will effect the range. Try different mounting locations and positions in the vehicle. If operation is still undesirable, the problem may be isolated by:

1. Checking the door operator. If the door will not open when the wall button is pressed, the problem is likely to be the operator. If the door will open by pressing the wall button, but not when the radio control button is pressed, the problem is probably in the radios.
2. Replacing the transmitter battery.

If, after performing the above operational checks, the controls still do not function, they should be returned to your dealer for repair or replacement.

WARRANTY

All Digi-Code door related products carry an eighteen (18) month warranty against defects in workmanship or material. This warranty begins at the date of manufacture, for eighteen months. Digi-Code warrants our product only to our authorized dealers and distributors, and not to the end customer. If you have any questions about our warranty, please ask your dealer to determine the nature and scope of their warranty. Digi-Code does not assume, and is not responsible for, any real or consequential damages from claims against the performance of our product, nor is it liable for any costs related to the loss of life, property, or revenue. Further, Digi-Code is in no way responsible for installation of our product, and will assume no cost related to reinstallation or removal. Digi-Code's warranty is in lieu of all other warranties, expressed, or implied.

CAUTION: Any changes or modifications in intentional or unintentional radiators which are not expressly approved by Digi-Code Inc. could void the users authority to operate this equipment. This applies to intentional and unintentional radiators certified per part 15 of the FCC rules and regulations.

DIGI-CODE, INC.

Part # 72-5010